

SPECIFICATIONS

Design	3200 Lit./min(50Hz)
Displacement	4000 Lit./min(60Hz)
Speed	1400 r.p.m. (50Hz)
	1750 r.p.m. (60Hz)
Normal usage vacuum pressure	Under Torr
Attainable vacuum pressure	Max 22.5Torr ^33mber
Suction port diameter	DIN 50A (2) IN&OUT
Motor Sepec IP 55	(IEC250) 3-Phase 200/460V50^ 60Hz 8.6kW 4P
Maker Water Capacity	15°C 25 L/MIN
Weight	145 Kg
Deswibil	72 db(A)
Painting	Company's standard Color- 0000
Rotation	Clokwise in motorized fan

-1 Excluding motor and some other parts.

Curve referred to dry air at 20°C (68°f) 배 기 량 SUCTION CAPACITY

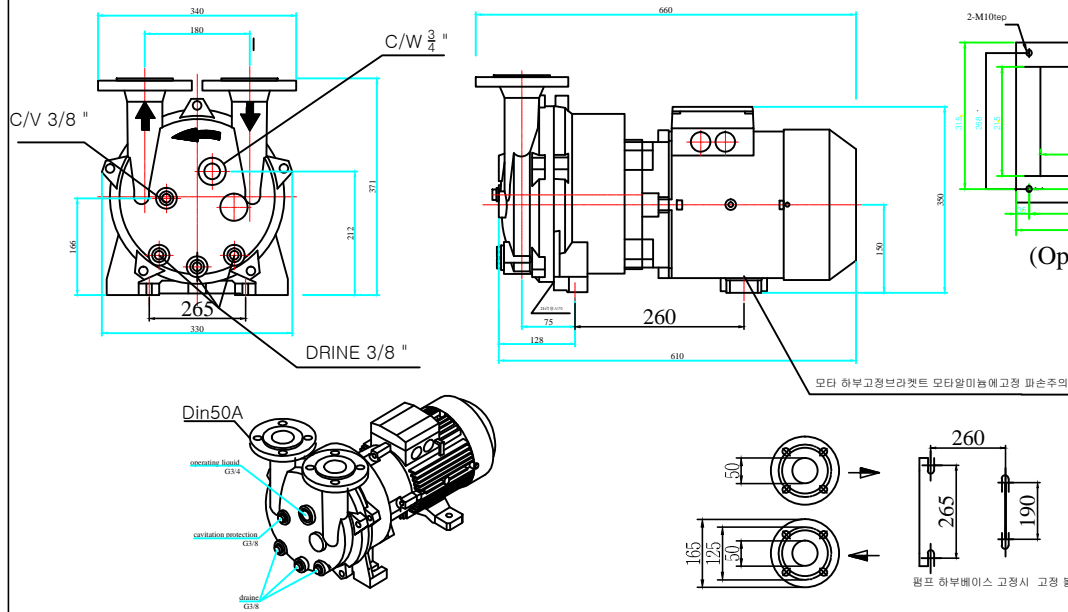
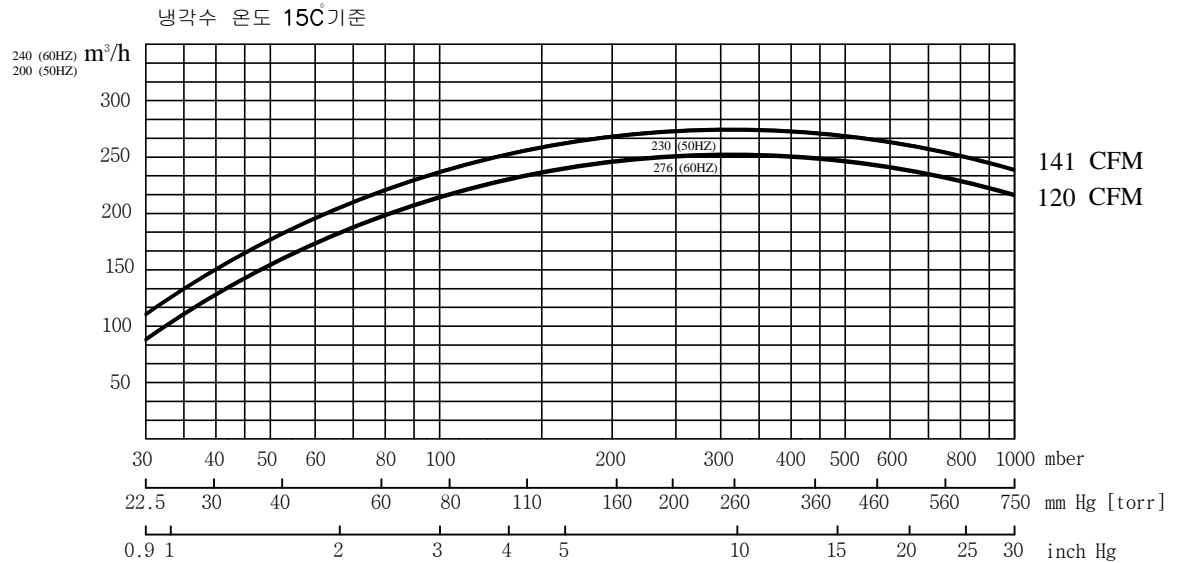

ACCESSORIES (Option)

- Vacuum Manual Valve
- Vacuum gauge
- Vacuum Check Valve
- Separator Tank
- Base
- Water inlet s/v
- Cavitation Valve

CONSUMABLE LIST

(Vacuum.ENG GENUINE PARTS)

Designation	Specification	Quantity/set
M/C Seal	Bellows Type ϕ 55	1
Bearing	F #6308 R#6208 Heat - resisting grease	1

DWG DATE	SCALE		TITLE
2018.09.04	N/S		WATER RING V/P
DWGBY	DESBNY	CHDBY	APPROVE
			LOCATION
진공엔지니어링			DWG NO
			JDLP-9MM

- 품질 개선을 위해서 예고없이 변경 될수 있음.
- Not binding dimension that can change according to motor make